

Model: Schmidt1		Date: 04-Jul-00	No.: RH545009
Subject: New Model Schmidt1 Light (US version) Release		Prepared by: K. Misugi	
From: Technical Services Dept., GTS Division			
Classification:	<input type="checkbox"/> Troubleshooting	<input type="checkbox"/> Part information	<input type="checkbox"/> Action required
	<input type="checkbox"/> Mechanical	<input type="checkbox"/> Electrical	<input type="checkbox"/> Service manual revision
	<input type="checkbox"/> Paper path	<input type="checkbox"/> Transmit/receive	<input type="checkbox"/> Retrofit information
	<input checked="" type="checkbox"/> Other (New Model Release Information)		

The new model Schmidt1 Light - US (FAX1900L) will be released in the line-up of the Schmidt1 (FAX2000L) series.

This technical bulletin is to inform the differences between the Schmidt1 Light and the Schmidt1. They are listed in order of sections that appear in the service manual.

NOTE: The Schmidt1 Light has already been released in the European market.
This machine is not available in the Asian market.

1. OVERALL MACHINE INFORMATION

1.1. SPECIFICATIONS

Item	Schmidt1	Schmidt1 Light
1 MB Memory (Optional)	Available	Not Available (No longer manufactured.) Only the 2 MB memory option is available.
Multi-purpose Feeder (Optional)	Available	Not Available
Paper Feed Unit (Optional)	Available	Not Available
Print Resolutions Printer Mode	600 x 600 dpi	The PC option is not available
Dimensions (W x D x H)	399 x 730 x 323 mm	399 x 707 x 299 mm The document table extension (P/N: H5454314) is not available.

Model: Schmidt1	Date: 04-Jul-00	No.: RH545009
-----------------	-----------------	---------------

1.2. FEATURES

Features Comparison Table

Features	Schmidt1	Schmidt1 Light (US version)
Equipment		
Optional cassette (Multi-purpose feeder)	Available	Not available
Optional paper feed unit	Available	Not available
Optional printer interface	Available	Not available
Communication Features		
Batch transmission	Max 35 files	Not available
Other User Features		
Center mark	Available	Not available
Quick dial label printing	Available	Not available
Specified cassette selection	Available	Not available
Blank Document Detection (Not listed in the features list.)	Available	Not available

2. DETAILED SECTION DESCRIPTIONS

2.1 SCANNER

Scanning Speed

The scanning speed (during memory tx) for each resolution is as described below. Please note that this description is not mentioned in the Schmidt1 service manual.

Resolution	Scan Speed (A4)	
	Schmidt1	Schmidt1 Light
Standard	2.8 s	5.6 s
Detail	5.6 s	5.6 s
Fine	11.3 s	11.3 s

Model: Schmidt1

Date: 04-Jul-00

No.: RH545009

3. PARTS CATALOG INFORMATION

The following parts for the Schmidt1 Light are different from the Schmidt1.

Index	Schmidt1	Schmidt1 Lite	Description
3-6	H5454400	Not used	Handset Bracket
3-7	H0814141	Not used	Screw - Handset
3-8	H5054178	Not used	Stay - Handset
3-9	H5454401	Not used	Handset Bracket Ass'y
3-12	H5454330	Not used	Fan cover
3-16	H5454314	Not used	Document Table Extension
3-19	H5454368	H5454331	Decal - Paper Jam
3-26	H5456080	Not used	PC I/F Board
3-27	G0121165	Not used	Knob Screw
3-28	H5458600	H5458660	Operation Manual - Lite (RIC-US)
	H5458630	H5458631	Operation Manual - Lite (Savin)
3-30	H5458670	H5458677	Installation Procedure - Lite - US
3-34	H5517258	Not used	Ferrite Core
5-1	H5454600	H5454615	Operation Panel Ass'y - Lite (RIC-US)
5-1	H5454605	H5454618	Operation Panel Ass'y - Lite (Savin)
9-21	H5164095	Not used	Decal - Energystar
11-21	H5455151	Not used	Ground Wire
17-28	H5455116 (modified to H5455138)	Not used	Main Harness - Multi-purpose
19-22	H5454101	H5474101	Right Side Plate
21-13	H5456120	H5456122	PCB - FCU - Lite US
23-16	H5454213	Not used	Decal - Parallel
23-20	H5455115 (modified to H5455137)	Not used	Main Harness - 2nd
25-13	H5453128	H5453204	Paper Feed Bracket - Lite
25-21	H5455151	Not used	Ground Wire
25-22	H5453189	H5473189	Magnetic Clutch Bracket
25-24	H5453174	Not used	Idler Gear 2 - 14Z



Model: Schmidt1	Date: 04-Jul-00	No.: RH545009
-----------------	-----------------	---------------

25-25	H5453173	Not used	Idler Gear 1 - 23Z
25-26	H5453171	Not used	Gear 2 - 31Z
25-27	H5453172	Not used	Gear 3 - 16Z
-26	---	H5453199	Slow Down Gear - Lite (Please refer to the following diagram.)

NOTE: Please refer to the following diagram for the location of H5453199 (Index No. 26). This illustration is extracted from page 1-24 of the parts catalog.

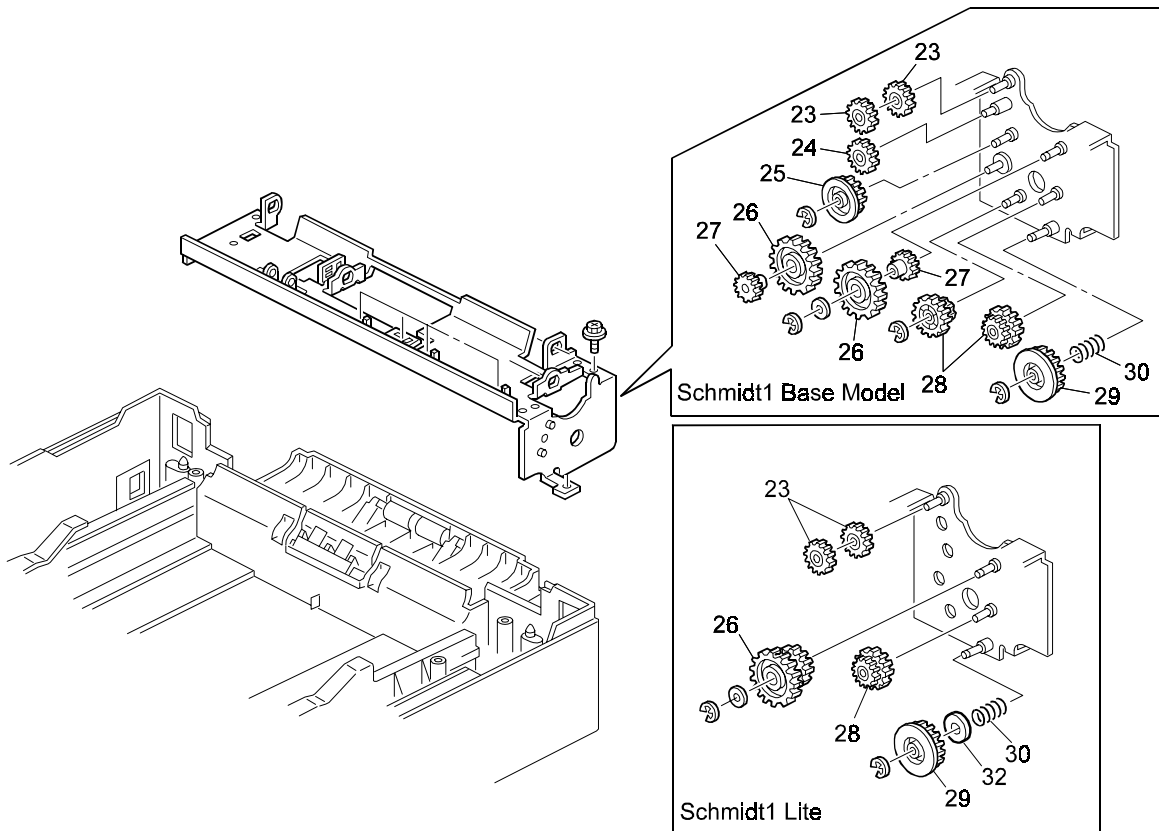

Model: Schmidt1

Date: 04-Jul-00

No.: RH545009

4. PRODUCT INFORMATION

Model Code	Model Name	Product Code	Serial #
Schmidt1 Lite (RIC-US)	FAX1900L	H545-24	A26 Y MM 00001
Schmidt1 Lite (Savin/Ges)	Savin Fax3705 Gestetner 9877	H545-28	A27 Y MM 00001